



## DESTROYER GRINDER

Built for Strength

EF-30LR  
EF-50LR  
EF-60LR  
EF-72LR

**CUSTOM MADE  
IN THE U.S.A.**

Rippings  
Cut-offs / Blocks  
Particle Board  
Pallets



## EF-30-50-60-72 LR END FEED GRINDERS

The EF-30 to 72 grinders are part of Cresswood's "Destroyer Series" of very large, yet general purpose grinders, with the added efficiency of a horizontal fed grinder. They are designed for pallet companies, large furniture manufacturers and other companies wishing to dispose of whole pallets, cants or slabs up to 7+ inches thick and 72 inches wide. They are also able to handle very long strips right off straight line rip or gang saws and can reduce skeletons from a router. Ideal for size reduction, the EF's throughput can be optimized for your application with a choice of screens, cutters, cutter placement, and rotor selection.

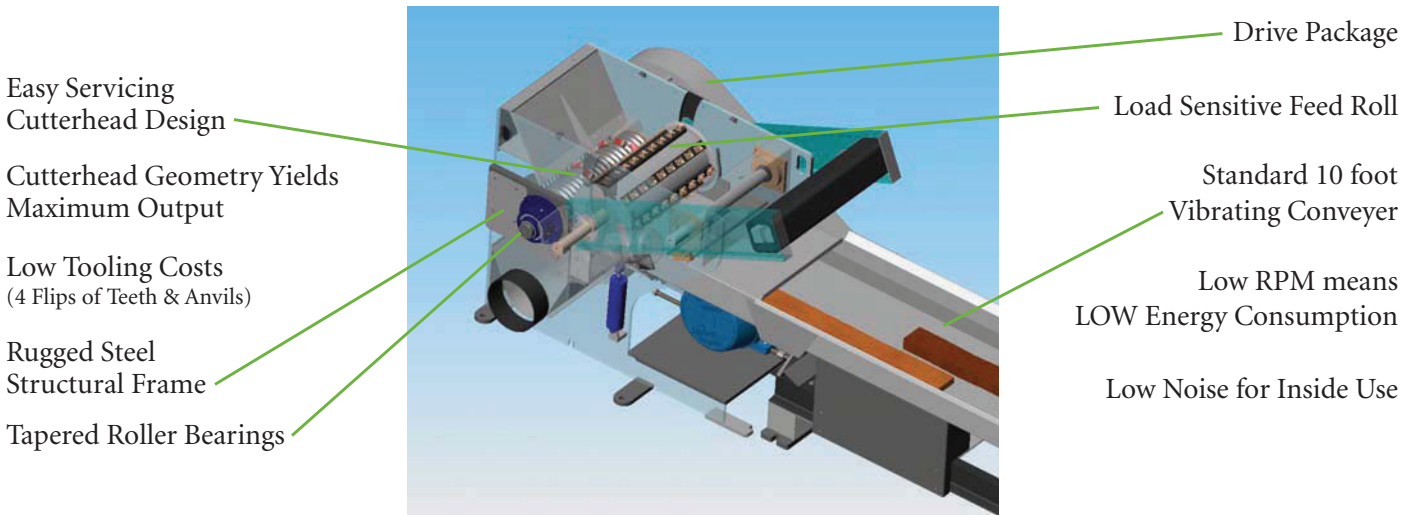

Easy Servicing  
Cutterhead Design

Cutterhead Geometry Yields  
Maximum Output

Low Tooling Costs  
(4 Flips of Teeth & Anvils)

Rugged Steel  
Structural Frame

Tapered Roller Bearings

Drive Package

Load Sensitive Feed Roll

Standard 10 foot  
Vibrating Conveyer

Low RPM means  
LOW Energy Consumption

Low Noise for Inside Use

## Specifications

	EF-30LR	EF-50LR	EF-60LR	EF-72LR
Motor HP	60, 75, 100	60, 75, 100	75, 100, 125	75, 100, 125
Infeed Conveyor	12' Vibrating	12' Vibrating	12' Vibrating	Not Included
Grinding Head Diameter	16"	16"	16"	16"
Grinding Head Length	30"	50"	60"	72"
Grinding Head Speed	400-600 rpm	300-600 rpm	300-600 rpm	300-400 rpm
No. of Cutter Teeth	42	70	84	120
Floor Area of Unit	60" x 168"	81" x 190"	97" x 190"	105" x 195"
Input Capacity	8" x 30"	7.5" x 50"	7.5" x 60"	7.5" x 72"
Frame Thickness	3/4"	3/4"	1"	1"
Shipping Weight	7,500 lbs.	8,500 lbs.	10,000 lbs.	10,500 lbs.
Specifications are subject to changes				



55 W. Lincoln Highway • Cortland, Illinois 60112  
800-962-7302 • Fax: 815-758-0733 • [www.cresswood.com](http://www.cresswood.com)