



## DESTROYER GRINDER

*Built for Strength*

**EF-24SR**  
**EF-36SR**

**CUSTOM MADE  
IN THE U.S.A.**

Rippings  
Cut-offs / Blocks  
Particle Board



## EF-24SR AND EF-36SR END FEED GRINDERS

The EF-24SR and EF-36SR horizontal end feed grinders feature a 24" to 36" rotor length and a 10" diameter rotor. These are Cresswood's most versatile end feed wood grinders. They can automatically eliminate all the waste generated by small band saws, resaws, gang rip saws and blocks from chop saws. These versatile machines can be used as dedicated grinders for a high-speed panel saw or gang rip saw. The EF-24SR and EF-36SR grinders, with their small footprints and low profiles, allow placement of the grinders in close proximity to the waste stream which saves on labor. They are the ideal wood grinders for small furniture, cabinet, and woodworking companies and for those in the animal bedding market.

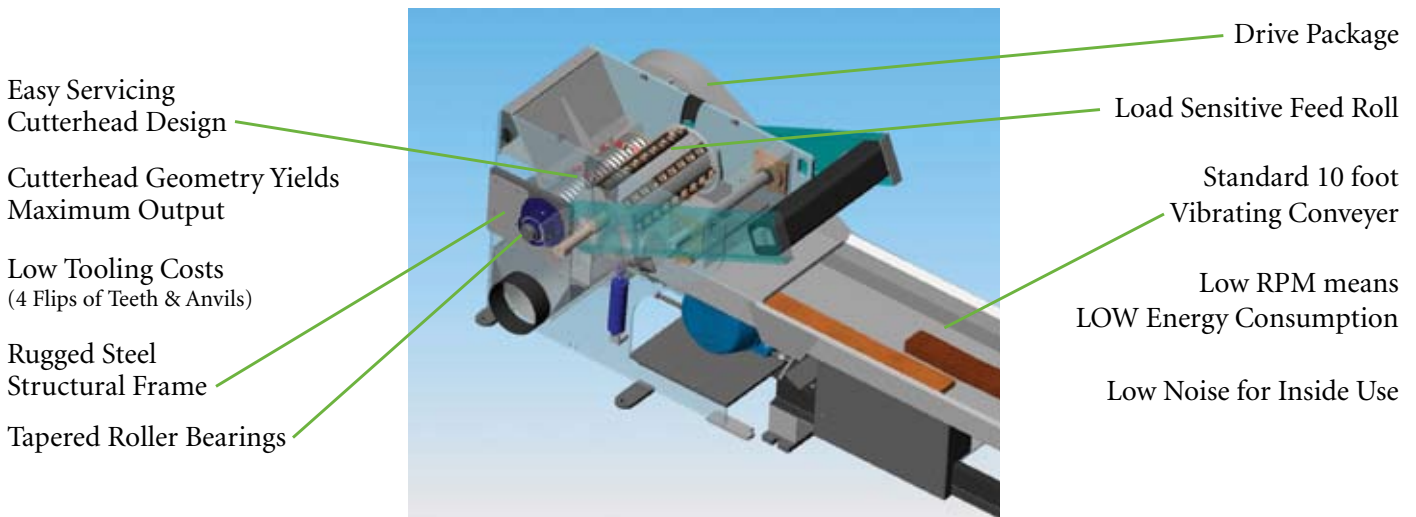

## Specifications

	EF-24SR	EF-36SR
Motor HP	30, 40, 50	50
Infeed Conveyor	10' Vibrating	10' Vibrating
Grinding Head Diameter	10"	10"
Grinding Head Length	24"	36"
Grinding Head Speed	300-400 rpm	300-400 rpm
No. of Cutter Teeth	40	60
Floor Area of Unit	52" x 157"	67" x 156"
Input Capacity	5" x 24"	5" x 36"
Frame Thickness	3/4"	3/4"
Shipping Weight	3,700 lbs.	5,000 lbs.
Specifications are subject to changes		



55 W. Lincoln Highway • Cortland, Illinois 60112  
 800-962-7302 • Fax: 815-758-0733 • www.cresswood.com