



DESTROYER GRINDER

Built for Strength

EF-12SR

CUSTOM MADE
IN THE U.S.A.

Rippings
Cut-Offs



EF-12SR END FEED GRINDER

The EF-12SR is the smallest member of Cresswood's "Destroyer Series" product line. It will eliminate rippings and occasional blocks. The EF-12SR grinder, with its small footprint and low profile, allows placement of the grinder in close proximity to the waste stream which saves on labor. This is the ideal grinder for small furniture, cabinet, woodworking and millwork shops.

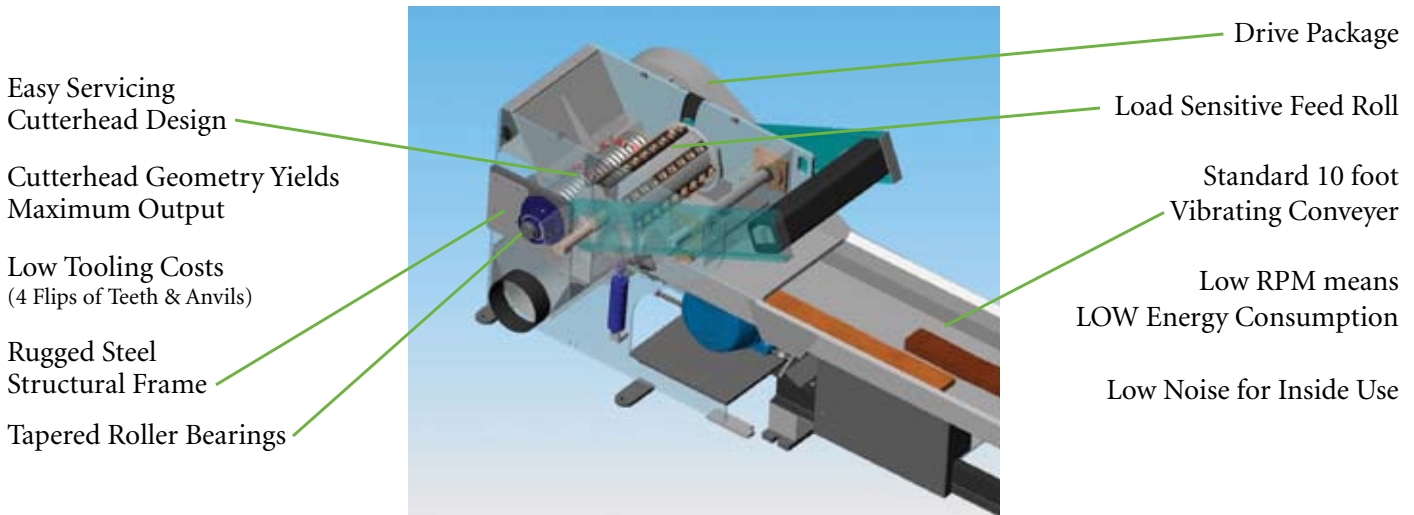

Specifications

	EF-12SR
Motor HP	25, 30
Infeed Conveyor	10' Vibrating
Grinding Head Diameter	10"
Grinding Head Length	12"
Grinding Head Speed	300-600 rpm
No. of Cutter Teeth	20
Floor Area of Unit	35" x 153"
Input Capacity	4" x 12"
Frame Thickness	3/4"
Shipping Weight	2,800 lbs.
Specifications are subject to changes	



55 W. Lincoln Highway • Cortland, Illinois 60112
800-962-7302 • Fax: 815-758-0733 • www.cresswood.com