



DESTROYER GRINDER

Built for Strength

HF-7870 XR

**CUSTOM MADE
IN THE U.S.A.**

**Paper Recycling
Printing Paper Waste
Secure Information Destruction**



HF-7870 XR HOPPER FEED SHREDDER

The HF-7870 XR “Mega Destroyer” is the largest one-pass top feed shredder in Cresswood’s product line, weighing in at 23,000 pounds. The 7870 is equipped with a 70” long, 20” diameter XR V-rotor cutterhead, innovative ram and control technology to maximize throughput, and an expanded cutting chamber to accommodate and destroy large volume and/or large sized materials. This 15’ long “Mega Destroyer” powerhouse is built to solve the larger size reduction needs for the paper recycling, printing paper waste, and secure information destruction industries.

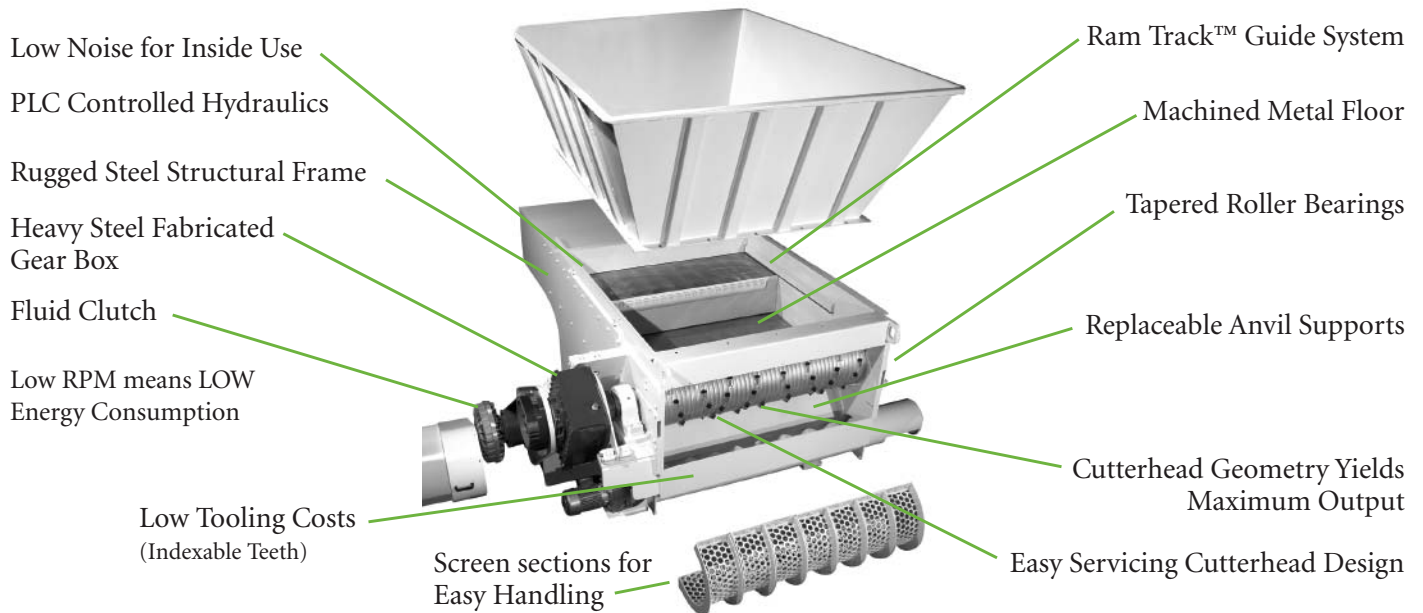

Specifications

	HF-7870 XR
Motor HP	125, 150
Cutting Chamber	70" X 78"
Ram Stroke	60"
Grinding Head Diameter	20"
Grinding Head Speed	50-150 rpm
Frame Thickness	1"
No. of Cutter Teeth	98
Shaft Diameter	5"
Hopper Opening	90" x 70"
Floor Area of Unit	108" x 178"
Shipping Weight	23,000 lbs.
Specifications are subject to changes	

Machines shown with options



55 W. Lincoln Highway • Cortland, Illinois 60112
 800-962-7302 • Fax: 815-758-0733 • www.cresswood.com